

Quarter Turn Fasteners & Parts

Inch

Fixations quart de tour et pièces

Pouce

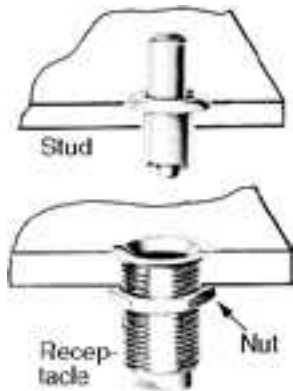

**15 F Series
4-Part
PUSH BUTTON
FASTENER**

A totally new kind of fastener that is as easy to install as it is to operate. One push of the button releases - one push locks. Single hole mounting cuts installation costs. No rivet holes, no riveting, no expensive tooling - for rapid production line installation. 300lbs. ultimate tensile strength.

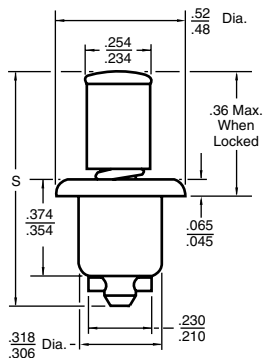

STUD INFORMATION

SPAENAUR No.	G = Grip Range	S ±.02	G =
110-001	.030-.089"	.91	Outer Panel P plus gaskets, paint, etc.
110-003	.090-.149"	.97	+ .015 (clearance)
110-007	.210-.269"	1.09	

PKG QTY. 1

Finish: Bright Nickel Plate

INSTALLATION DATA For STUD

Outer Panel: Drill .323 dia. hole. For panels thicker than .188, back counterbore to a remaining thickness of .188 max. Install stud and retainer as shown.

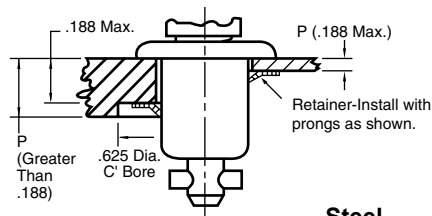

**Steel,
Nickel Plated**

RECEPTACLE

SPAENAUR No.	FINISH	WT. - LB./100
110-018	Cadmium Plated W/Clear Chromate	.987

INSTALLATION DATA For RECEPTACLE

PKG QTY. 1

Inner Frame: For frames thicker than .080, drill .484 dia. (.31/64 drill) hole and countersink 100° to .625" dia. x .015 deep.

For frames thinner than .081, drill .406 dia. (13/32 drill) hole, dimple 100° to .670 dia. with .484 dia. clearance hole.

Place receptacle in hole and secure with nut as shown.

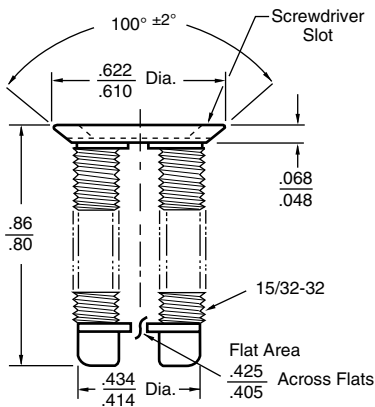

RECEPTACLE - Zinc Alloy

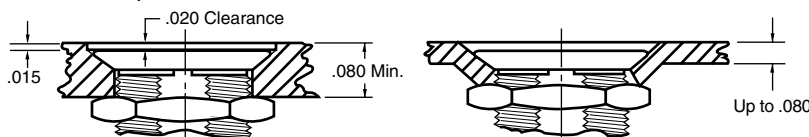

RETAINING NUT

15/32"-32 NS-THREAD

To fit Receptacle Above (Spaenaur No. 110-018)



Width - 9/16"
Across Flats
Thickness - 3/32"

SPAENAUR No.	MATERIAL	FINISH	WT.-LB./100
110-020	Steel	Cad, Gold Chromate Plated	.13

PKG QTY. 1

RETAINER

To fit Receptacle Above (Spaenaur No. 110-018)

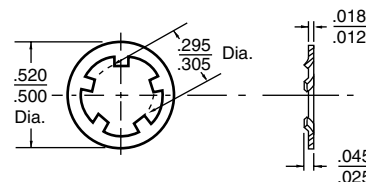

SPAENAUR No.	FINISH	WT.-LB./100
110-019	Zinc Plated with Chromate Finish	.045

PKG QTY. 1

SPECIFICATIONS:

Stud, Retainer and Nut: Steel Receptacle: Zinc Alloy
Vibration: Meets Specification Mil-F-5591 with 25 lb. load.
Endurance: Meets Specification Mil-F-5591
Operable after 50 hours salt spray test.

Inch

50 F Quarter Turn Fastener Parts

Pouce

Pièces pour fixations quart de tour 50F

Eliminate Hang-ups with this Compact "50F" Clip-on Quarter Turn Assembly

- EASY TO INSTALL
- LOW PROFILE
- SAVE ON INSTALLATION COSTS

- EASY TO REMOVE
- NO SPECIAL TOOLS

STEEL
with Zinc Plated
Gold Chromate Finish

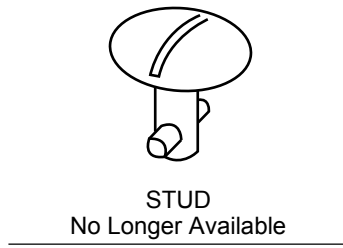

CLIP-ON RECEPTACLE
SPAENAUR No. 110-B01-1X

Only one size needed
PKG QTY. 100

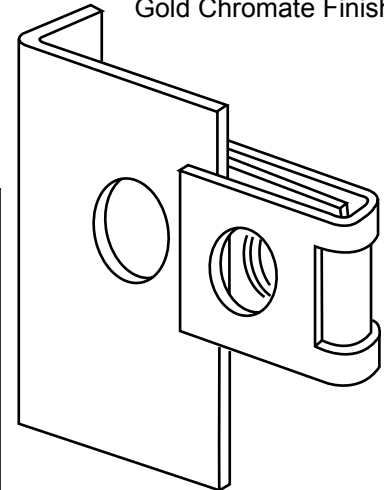
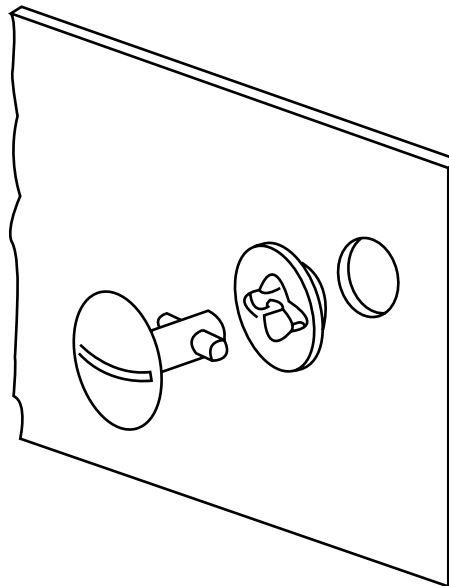

This new "50F" clip-on quarter-turn receptacle eliminates annoying stud hang-up when you open your panel. There's no interference from protruding edges in the housing. The stud meets only rounded metal as you twist it out. This gives you the smooth operation you can really appreciate.

The receptacle is easy and economical to install. You simply slide it on over your prepunched hole. Install the stud and retainer in your panel (all it takes is a push of your thumb) and you're ready. It's easy to remove the clip-on receptacle too. Just pry it off with a screwdriver.

The 50F 1/4 Turn Receptacle is the most compact clip-on fastener you can buy and its low profile takes up less space in those tight places.

Patent Pending

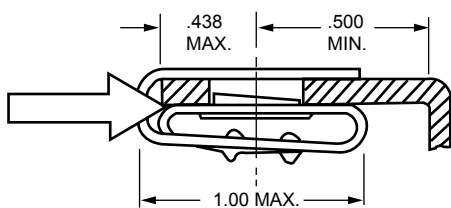

Pry or lift apart as shown by arrow to disengage retaining lip from hole and slide off.

INSTALLATION DATA

DIMENSIONS IN INCHES

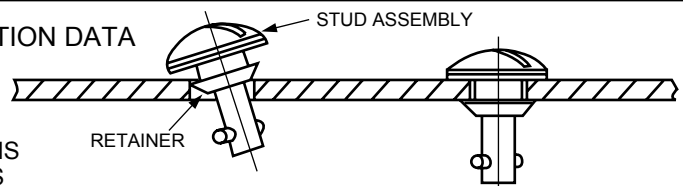

INSTALLING STUD ASSEMBLY

1. Insert Stud thru Retainer then thru Panel.
2. Tap Stud with Hammer to Seat Retainer in Panel.

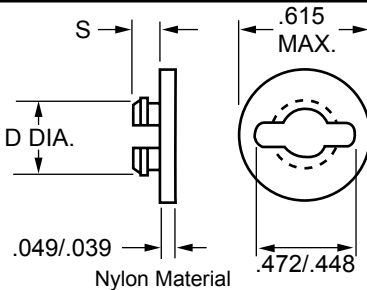

PKG QTY. 100

STUD RETAINER SELECTION

Retainer SPAENAUR No.	D Max.	S Max.	P Panel Max.	Panel + Frame P + F Min.	Installation Mounting Hole Dia.
110-051	.348"	.140"	.062"	.032"	.315 - .320"
110-053	.390"	.252"	.162"	.144"	.357 - .362"
110-054		.302"	.212"	.194"	
110-055		.352"	.262"	.244"	

CATALOG 14

SPAENAUR

91 F Quarter Turn Fasteners

Inch

Fixations quart de tour 91 F

Pouce

Stud Assembly with WING HEAD

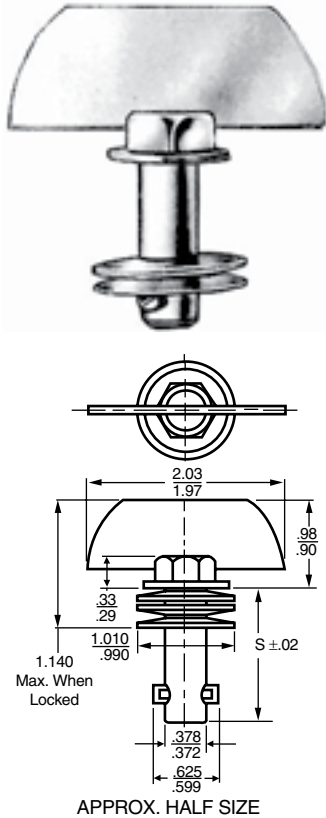

91 F Series Fastener Studs Bigger—Stronger Quarter Turns

Wing Head		Total Range Thickness "G"	S ±.02"	Slotted Hex. Head	
SPAENAUR No.	PKG QTY.			SPAENAUR No.	PKG QTY.
110-091	10	.035-.064"	.67"	110-115	10
110-092	10	.065-.094"	.70"	110-116	10
110-093	10	.095-.124"	.73"	110-117	10
110-094	10	.125-.154"	.76"	110-118	10
110-095	10	.155-.184"	.79"	110-119	10
110-096	10	.185-.214"	.82"	110-120	10
110-097	10	.215-.244"	.85"		
		.245-.274"	.88"	110-122	10
110-099	10	.275-.304"	.91"	110-123	10
110-100	10	.305-.334"	.94"	110-124	10
110-101	10	.335-.364"	.97"		
110-103	10	.395-.424"	1.03"		
110-104	10	.425-.454"	1.06"	110-128	10
		.455-.484"	1.09"	110-129	10
110-106	10	.485-.514"	1.12"	110-130	10
110-107	10	.515-.544"	1.15"	110-131	10
110-108	10	.545-.574"	1.18"	110-132	10
110-109	10	.575-.604"	1.21"	110-133	10
110-110	10	.605-.634"	1.24"	110-134	10
110-111	5	.635-.664"	1.27"	110-135	5
110-112	5	.665-.694"	1.30"	110-136	5
		.695-.724"	1.33"	110-137	5
		.725-.754"	1.36"	110-138	5

Stud Assembly with SLOTTED HEXAGON HEAD

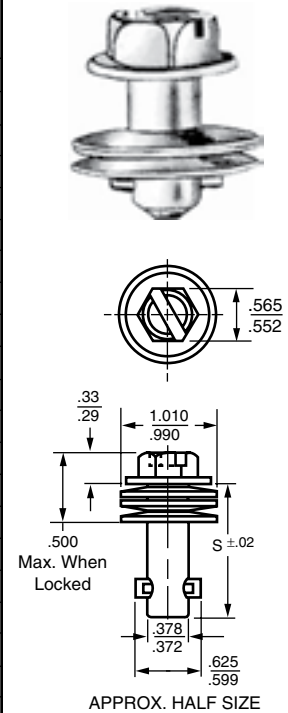

Material: STEEL
Finish: Zinc Plated & gold irridite
Temperature Range: to 232°C (450°F)

Illustration Dimensions in Inches.

1800 lbs. ultimate shear & tensile strength.
1200 lbs. rated shear & tensile strength.

GENERAL INFORMATION

TOTAL MATERIAL THICKNESS, "G" is comprised of the thickness of ALL materials to be fastened. This must include the thickness of the material, "P" to which the stud assembly is attached; the material, "F", to which the receptacle is attached PLUS gaskets (if used) and allowance for paint or other protective finishes.

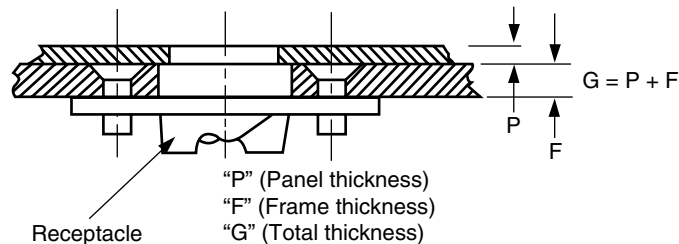

NOTE: Hole preparations are simple and provide 3/32" float in all directions to permit wide tolerances between outer panel and inner frame.



approx. 3/4 size

91 F Series

A rugged heavy duty quarter turn designed for those tough applications like farm and construction equipment, material handling equipment and more. Slotted, Wing, and Offset Wing head styles available. Higher clamping force with 1800 lbs. ultimate shear and tensile strength.

Continues on Next Page

Inch

91 F Quarter Turn Fasteners

Pouce

Fixations quart de tour 91 F

91 F Series - Continued

Illustration Dimensions in Inches.

NOTE: Three parts are required for a complete assembly, i.e.:

1. STUD
(selected from page L30)

2. RETAINING WASHER
(110-139 — left, below)

3. RECEPTACLE
(see below)

RETAINING WASHER

SPAENAUR
No. **110-139**

PKG QTY. **10**

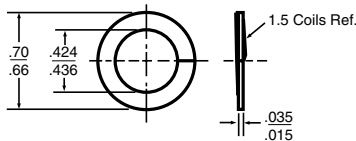

Material: STAINLESS STEEL
Temperature Range: to **288° C.**

RECEPTACLES

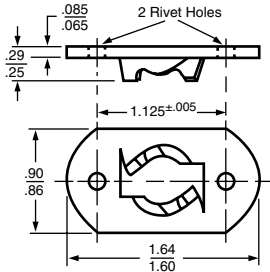

PLAIN RIVET

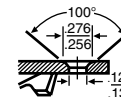

COUNTERSUNK RIVET

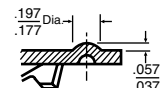

SPOTWELDING NIBS

SPAENAUR No.	Material	Temperature	Rivet Hole	Style	PKG QTY.
110-140	Steel	232° C	.128-.134"	PLAIN RIVET	10
110-141	Steel	232° C	.159-.165"		10
110-142	Steel	232° C	—	COUNTERSUNK RIVET	10

Receptacle Finish: Zinc plating, with gold irridite finish.

INSTALLATION DATA

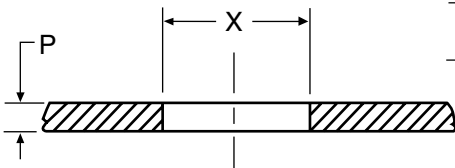

"P" panel thickness	"X" dia.
.001" to .125"	.562"
	.572"
.126" & up	.625"
	.635"

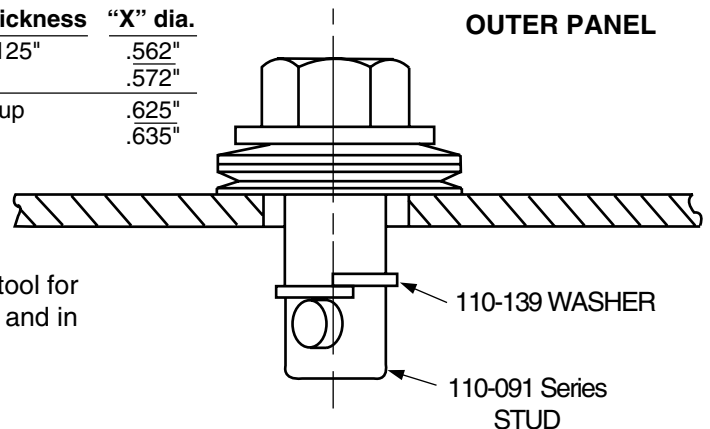

On custom installations, a hole-saw is the optimum tool for cutting the required circular holes in the outer panel and in the inner frame.

PLAIN Rivet Holes

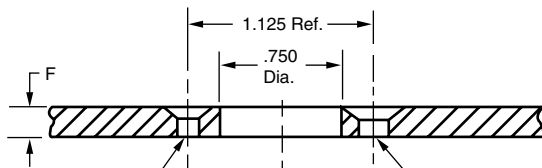

110-140 (2) Holes
Csk. for 1/8" Dia. Rivets

110-141 (2) Holes
Csk. for 5/32" Dia. Rivets

DIMPLED Rivet Holes

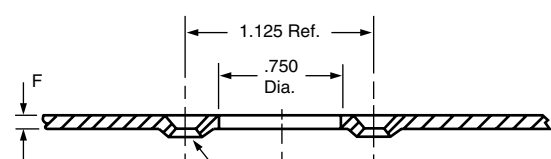

110-142 (2) Holes Dimpled
for 1/8" Dia. Rivets

More Quarter Turn Fasteners found on Page L147

Folding Handle Quarter Turn Fastener

Inch

Fixation de poignée quart de tour pliante

Pouce

Versatile, Low - Cost for Sheet Metal Applications

LIGHT DUTY STYLE

With Folding Handle

Available as separate parts or assembled.

SPAENAUR

No.	Description
110-025	Handle
110-026	Clip
110-027	Spring
110-028	Assembled, complete (Handle, Clip & Spring)



Components: STEEL
Finish: Cadmium Chromate
PKG QTY. 100

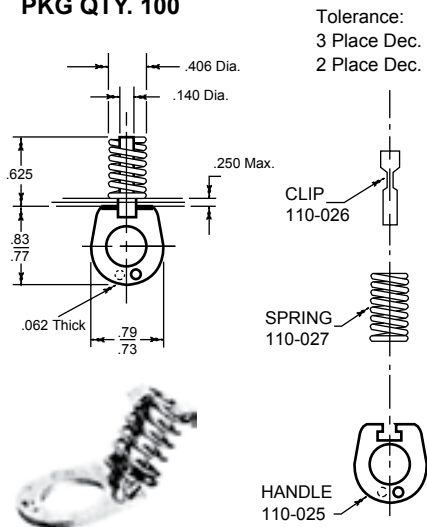

Tolerance:
3 Place Dec. ± .010
2 Place Dec. ± .02

All Dimensions in Inches.

MEDIUM DUTY STYLE

With Folding Handle

Available unassembled only.

SPAENAUR

No.	Description
110-029	Handle
110-030	Clip
110-031	Spring



Components: STEEL
Finish: Cadmium Chromate
PKG QTY. 100

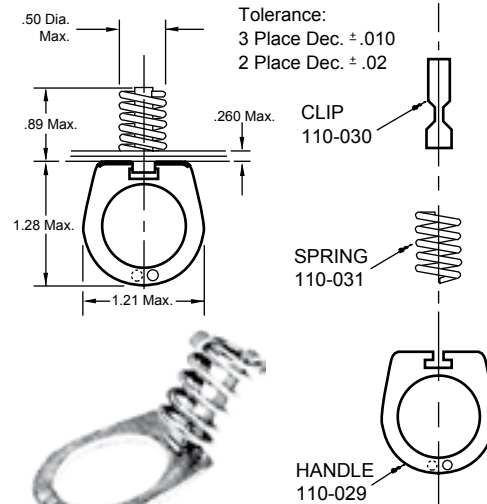

Tolerance:
3 Place Dec. ± .010
2 Place Dec. ± .02

L

INNER PANEL (BRACKET OR FRAME) PREPARATION FOR ASSEMBLED FASTENER: (Figure A) TO INSTALL:

1. Pass assembled fastener thru .500 dia. hole until base of handle is flush with surface of panel.
2. Pull handle & move fastener laterally thru .156 wide slot to .250 dia. hole.

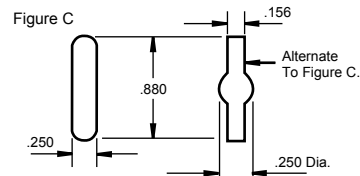
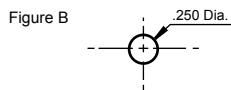
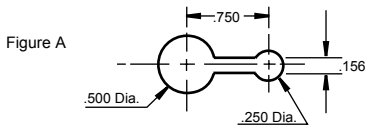

INNER PANEL (BRACKET OR FRAME) PREPARATION FOR UNASSEMBLED FASTENER: (Figure B) TO INSTALL: (No's. 110-025, -026 & -027)

1. Insert clip into spring.
2. Compress spring & pass clip into .250 dia. hole.
3. Compress spring to solid height & install handle to clip at narrow portion of clip.

OUTER PANEL PREPARATION: (Figure C) TO FASTEN:

1. When attaching outer panel to inner panel, handle will pass thru outer panel in vertical position.
2. Pull Handle & rotate 90° to secure to outer panel.

INNER PANEL (BRACKET OR FRAME) PREPARATION FOR UNASSEMBLED FASTENER: (Figure A) TO INSTALL:

(Same as at left except for hole diameter of .350.)

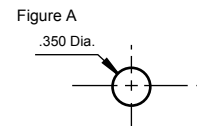

OUTER PANEL PREPARATION: (Figure B) TO FASTEN:

(Same as at left.)

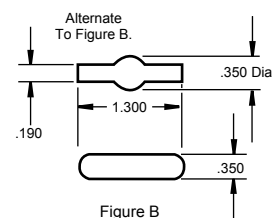

Also available
HEAVY DUTY STYLE.